



Whole-House Audio Control  
Owner's Manual

Controller Model: MC2-86

Home Theater Direct

Toll free: 866-HTD-AUDIO (483-2834)  
[www.htd.com](http://www.htd.com)  
[info@htd.com](mailto:info@htd.com)

# Safety instructions for the MC2-86

**Warning** - To reduce the risk of fire or shock, do not expose this appliance to rain or moisture.

**Caution** - To reduce the risk of fire or shock, do not remove the cover or back. No user serviceable parts inside. Refer servicing to qualified service personnel.

**Caution** - To prevent electric shock, match wide blade of plug to wide slot, fully insert.



The lightning flash with arrowhead symbol, within an equilateral triangle, is intended to alert the user to the presence of un-insulated dangerous voltage within the product's enclosure that may be of sufficient magnitude to constitute a risk of electrical shock to persons.

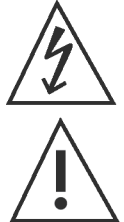

The exclamation point within an equilateral triangle is intended to alert the user to the presence of important operating and maintenance (servicing) instructions in the literature accompanying this appliance.

## Read Instructions

All the safety and operating instructions should be read before the appliance is operated.

## Retain Instructions

The safety and operating instructions should be adhered to.

## Heed Warnings

All of the warnings on the appliance and in the operating instructions should be adhered to.

## Follow Instructions

All operating and use instructions should be followed.

## Water and Moisture

The appliance should not be used near water. For example, near a bathtub, washbowl, kitchen sink, laundry tub, in a wet basement, or near a swimming pool, etc.

## Ventilation

The appliance should be situated so that its location or position does not interfere with its proper ventilation. For example, the appliance should not be situated on a bed, sofa, rug, or similar surface that may block the ventilation openings. Never place the appliance in a confined space such as a bookcase, or built-in cabinet, unless proper ventilation is provided.

## Heat

The appliance should be situated away from heat sources such as radiators, heat registers, stoves, or other appliances that produce heat. Position the appliance at least 4" away from any heat-producing amplifier, including HTD amplifiers.

## Power Sources

The appliance should be connected to a power supply only of the type described in the operating instructions or as marked on the appliance.

## Grounding or Polarization

Precautions should be taken so that the grounding or polarization means of an appliance is not defeated.

## Power Cord Protection

Route the power cord so that it is not likely to be walked on or pinched by items placed upon or against them, paying particular attention to the plugs, receptacles, and the point where the cord exits from the appliance.

## Cleaning

Unplug the appliance from the wall outlet before cleaning. Do not use liquid cleaners or aerosol cleaners. Use a cloth lightly dampened with water for cleaning the exterior of the appliance only.

## Non-Use Periods

The power cord of the appliance should be unplugged from the outlet when left unused for long periods of time.

## Object and Liquid Entry

Care should be taken so that objects do not fall and liquids are not spilled into the enclosure through openings.

## Damage Requiring Service

The appliance should be serviced by qualified personnel when:

- a) the power supply cord or the plug has been damaged
- b) objects have fallen, or liquid spilled into the appliance
- c) the appliance has been exposed to rain
- d) the appliance does not appear to operate normally or exhibits a marked change in performance or
- e) the appliance has been dropped, or the enclosure damaged

## Servicing

The user should not attempt to service the appliance beyond that described in the operating instructions. All other servicing should be referred to qualified service personnel.

## Product Servicing

If your system fails to operate properly, please contact HTD directly for further assistance at 1-866-483-2834.

Additional information, including detailed specifications for each model, can be found on our website, [www.htd.com](http://www.htd.com). Thanks again for choosing Home Theater Direct!

## Warranty

All HTD electronics carry a two-year parts and labor warranty. Warranty registration occurred automatically at the time your order was placed. There is no need to complete or mail in additional paperwork.

# Whole-House Audio Control Owner's Manual

## Introduction to the MC2-86 Whole-House Audio Control System

Thank you for your recent purchase of the HTD MC2-86 Advanced Whole-House Audio Control System! This new system is the most affordable system around that makes use of audio components located throughout your home. With this system you can independently select from up to 8 sources in 6 zones. Multiple MC2-86 and amplifiers can easily be combined for up to 16 zones.

Unlike most systems, the sources do not have to be located at a centralized point. Instead, you can have one source located within each zone that is available not only to that zone, but all other zones as well. Some examples: stream audio from a computer in one zone, connect the audio from a TV in another zone, or attach a CD player in another zone. For extreme convenience, we have included a 3.5mm (1/8") input jack on each keypad that overrides the source from that zone. So you can easily connect an MP3 player, iPod®, or other device and within seconds be streaming music throughout your home or office from it.

Of course, you can still connect audio sources directly to the MC2-86. And since our keypads pass along infrared signals, those sources can be controlled from within any zone with the use of your own remote control.

This owner's manual is designed to get you quickly up and running with your new system. Should you have any questions, we are available by phone, toll free 866-HTD-AUDIO (866-483-2834) M-F 8am-6pm, and by email at [info@htd.com](mailto:info@htd.com).

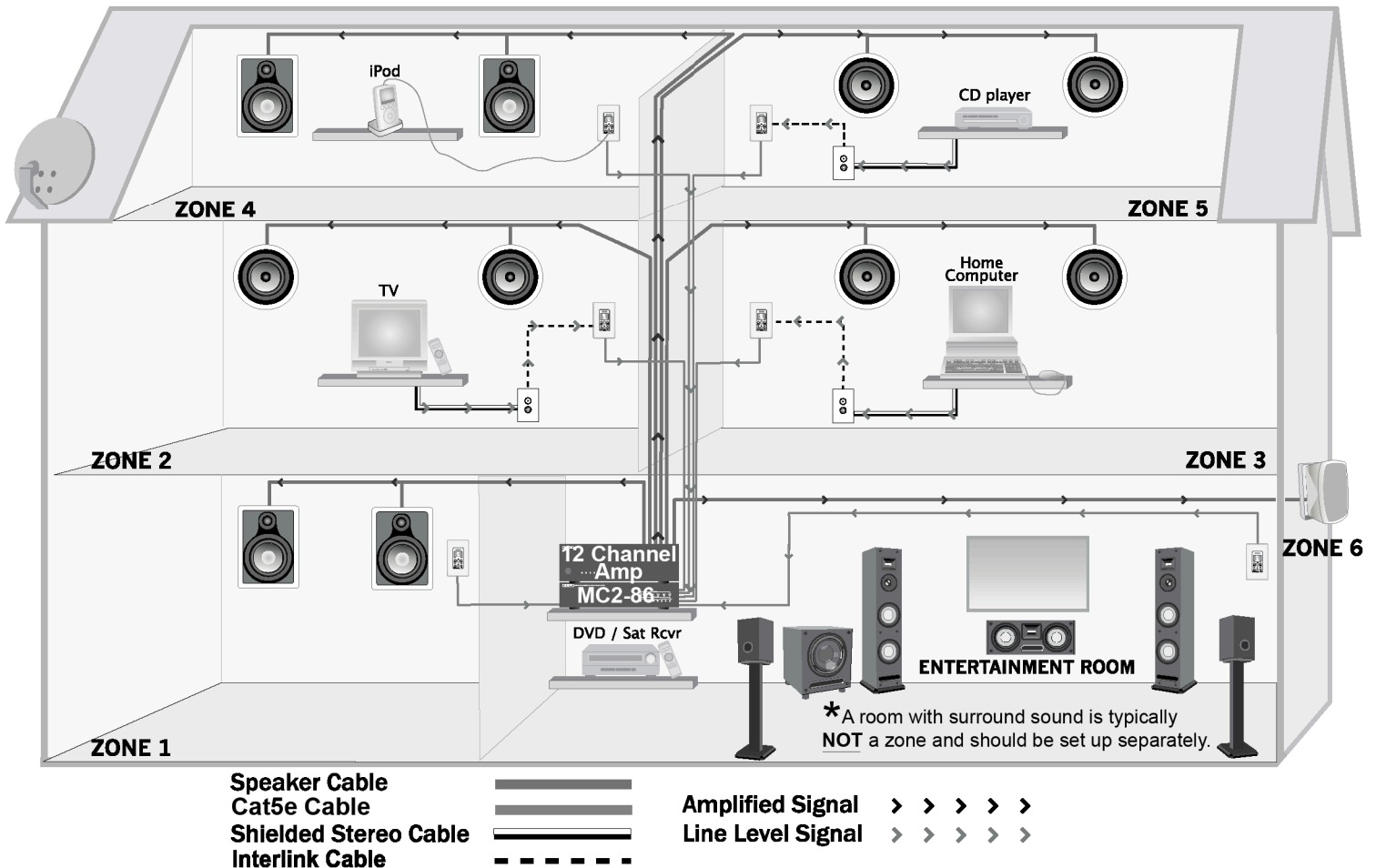

\*A room with surround sound (i.e. 5.1 or 7.1) will require a home theater receiver which has its own built-in amplification and multiple source inputs. For this reason, it is not typically set up as a zone on the whole-house audio system. However, it is possible to dedicate a zone on the MC2-86 to output to a stereo input on the home theater receiver. In this arrangement, you use the amps in the home theater receiver to power the zone instead of using two channels on the multi-channel amplifier. It is also possible for sources connected to the home theater receiver to be shared with the whole-house system through the use of Y-connectors (call us for details). For these two reasons, it is often a good idea to establish your central location in close proximity to the home theater receiver.

# Product Features

## MC2-86 Multi-Source / Multi-Zone Whole-House Audio Controller

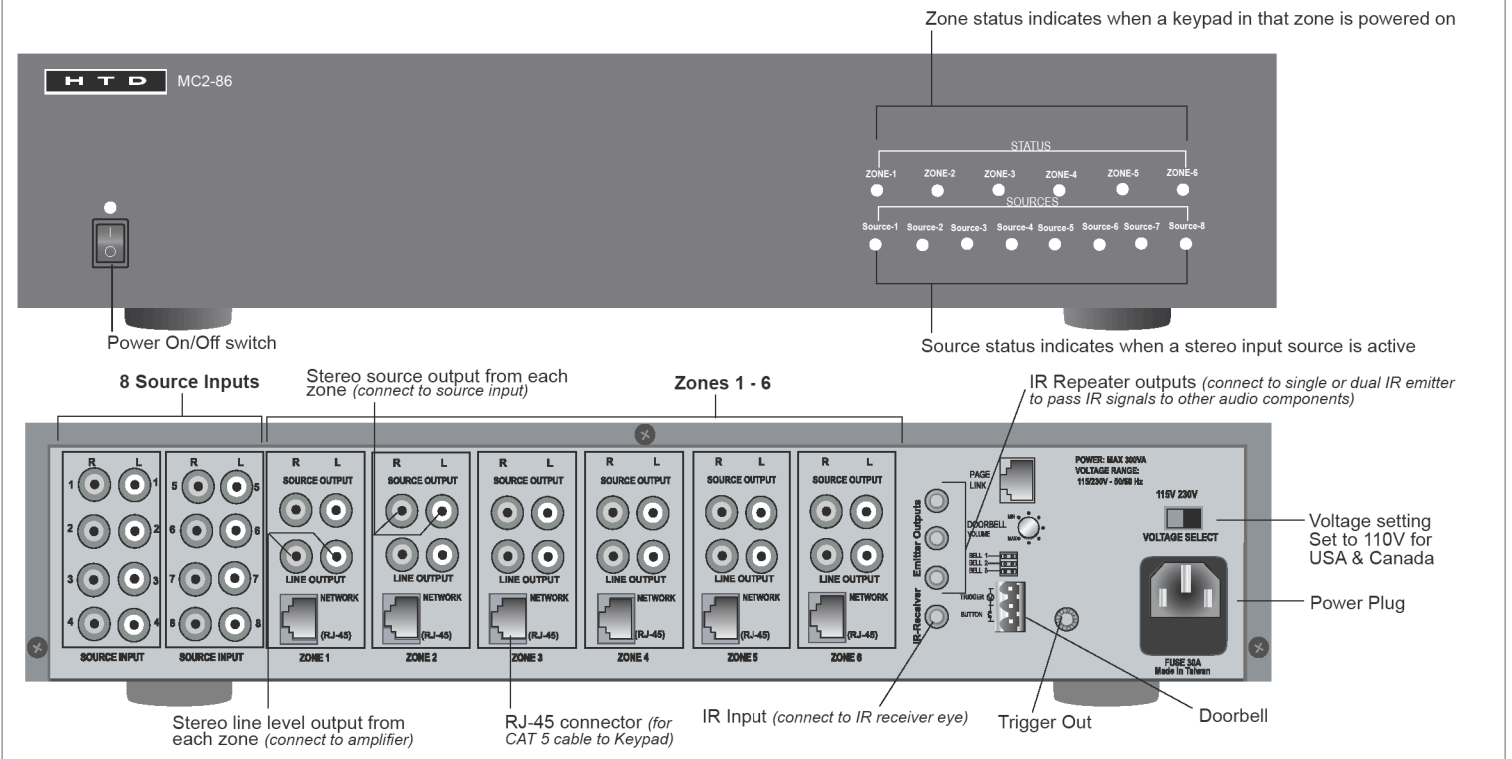

### Included with MC2-86

(6) Shielded Stereo Patch Cable (3 feet long)  
(for connecting MC2-86 to amplifier)

(6) Shielded Stereo Patch Cable (1 foot long)  
(for connecting zone Source Outputs to Source Inputs)

(1) Power cord



### Sold Separately

#### Keypad Control

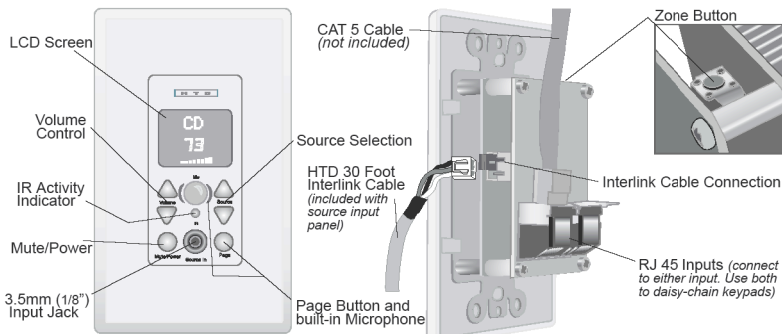

#### 3.5mm to 3.5mm Cables

For connecting an MP3 player, iPod®, etc. to 3.5mm input.

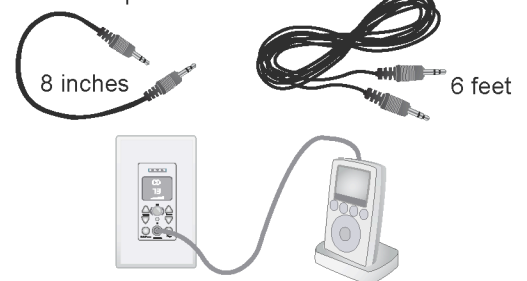

#### Source Input Panel

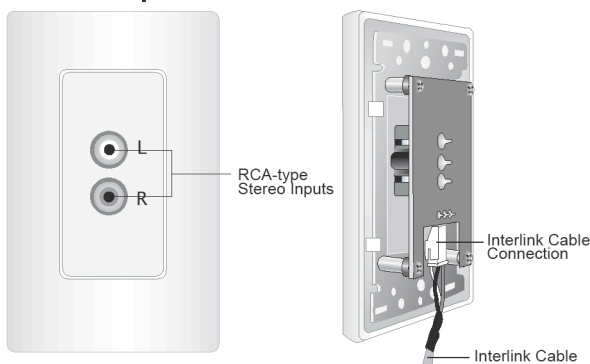

#### IR Emitters



Connect emitter(s) to the MC2-86 and place in front of other components that you want to control from within each zone.

#### IR Receiving Eye



Allows you to control audio components located near the MC2-86, even when hidden inside of a cabinet or closet.

#### Remote Control

Point at any keypad to select the source and to control the volume level in that zone.



# How to Connect

## Connection Overview

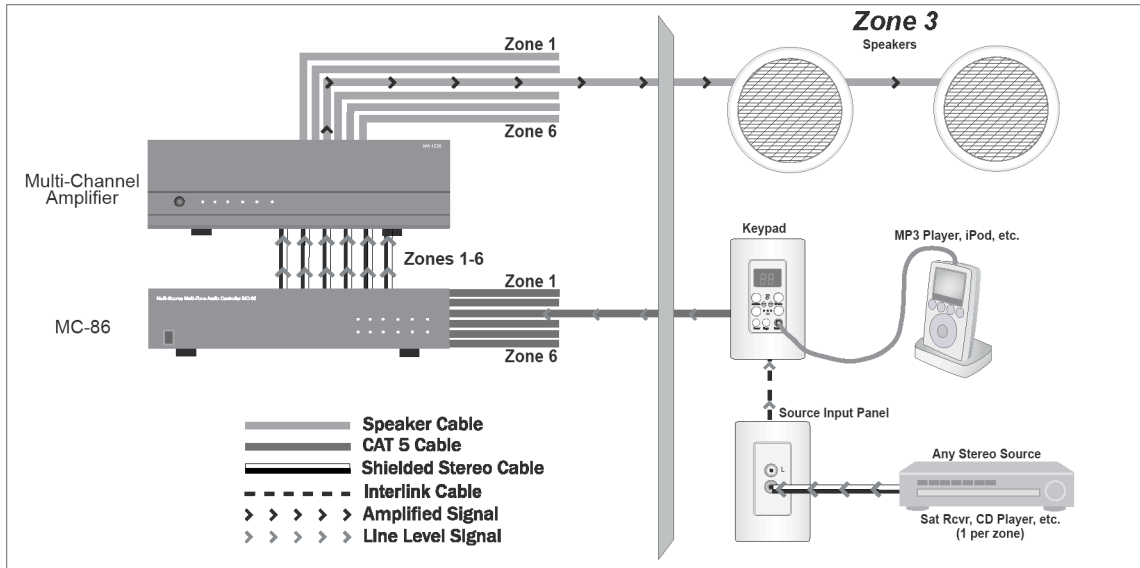

Think of the MC2-86 as the brain of the system. Based on information received from the keypads, it determines what source to play into each zone and the volume level to be sent to the amplifier.

### Keypad Connections (see page 5.)

The keypads are connected to the MC2-86 using Cat5e cable (Cat5, or Cat6 will also work and can be used in place of Cat5e throughout this manual) with RJ-45 connections at both ends. Keypads can be “daisy-chained” together with Cat5e cable but only one source can be connected per Cat5e cable that is connected directly to the MC2-86. For most installations, we recommend connecting at least one keypad from each zone directly to the MC2-86 in order to be able to connect a source within that zone (called a Zone Source).

### Source Input Panel Connections (see page 5.)

Although each keypad includes a 3.5mm (1/8”) source input jack for convenience, you may find it more practical to connect a source input panel to a keypad within each zone. The source input panel provides standard stereo RCA-type connections for connecting most audio components such as DVD players, CD players, TVs, VCRs and even computers. The source input panel can be located almost anywhere in the zone and is connected to the keypad with a special 30’ interlink cable that we include with each source input panel. A 60’ cable can be special ordered from our website.

### Amplifier Connections (see page 6.)

A stereo Line Output is provided on the MC2-86 for each zone. Each Line Output must be connected to its own amplifier in order for each zone to independently play its own source. The DMA-1240 and DMA-1275 12-channel amplifiers are a perfect fit with the MC2-86 because each provides 6 stereo (12 independent) channels of power. The Line Outputs on the MC2-86 are connected to the Line Inputs on the amplifier using six 3’ shielded stereo patch cables included with the MC2-86.

### Speaker Connections

Speakers are connected directly to the amplifier using speaker cable. For all behind-the-wall installations, CL3-rated cable is recommended to comply with most building-codes.

### Audio Component Connections (see page 7.)

Any audio component with a stereo analog RCA-type output can be connected directly to one of the 8 Source Inputs located on the back of the MC2-86 using RCA-type shielded stereo patch cables (not included).

### Assigning Zone Sources to a Source Input on the MC2-86 (see page 7.)

For each zone that includes an audio source within that zone (called a Zone Source), or to simply take advantage of the 3.5mm (1/8”) input jack on a keypad, on the back of the MC2-86 you will need to connect the Source Output from that zone to one of the Source Inputs. The MC2-86 includes six 1’ shielded stereo patch cables for this purpose.

### Trigger Out

Use the trigger output to automatically power up an external device with a low voltage trigger input whenever a Keypad is powered on. It is often a good idea to connect the Trigger Out to the Trigger In on the external multi-channel amplifier using a mono patch cable with 3.5 mm connectors. For your convenience, one is included with the MC2-86 controller. That way, the multi-channel amplifier will only be powered up when a Keypad is active. Once all Keypads have been powered off, the multi-channel amplifier will return to sleep mode.

# How to Connect (CONT'D)

## 2. Connecting a Keypad & Optional Source Input Panel

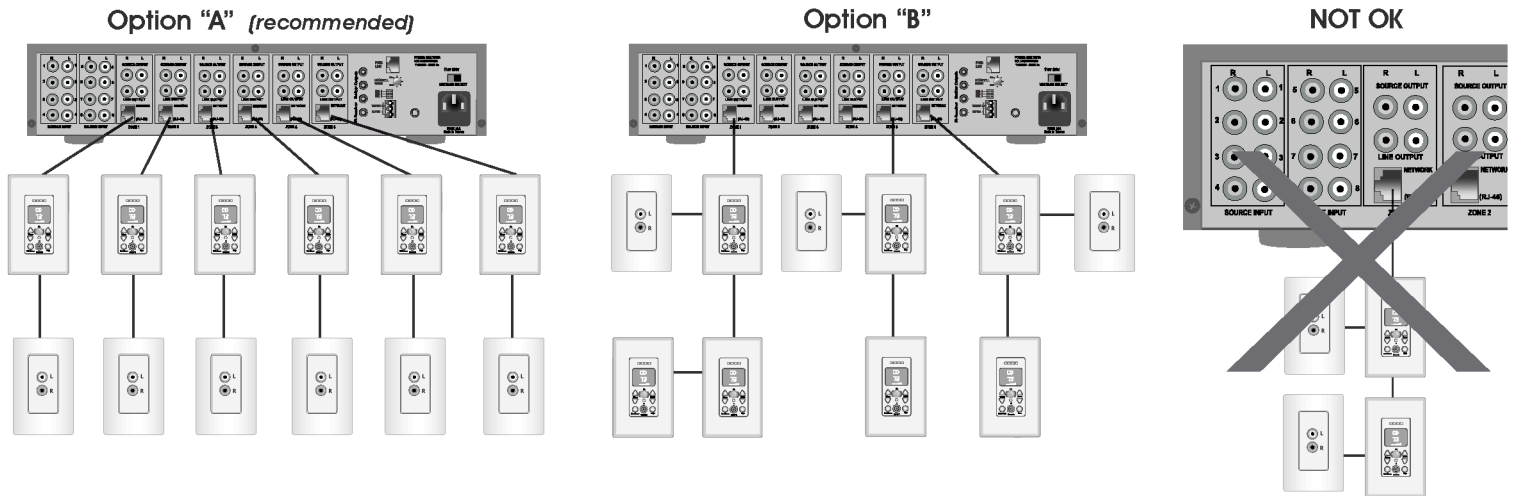
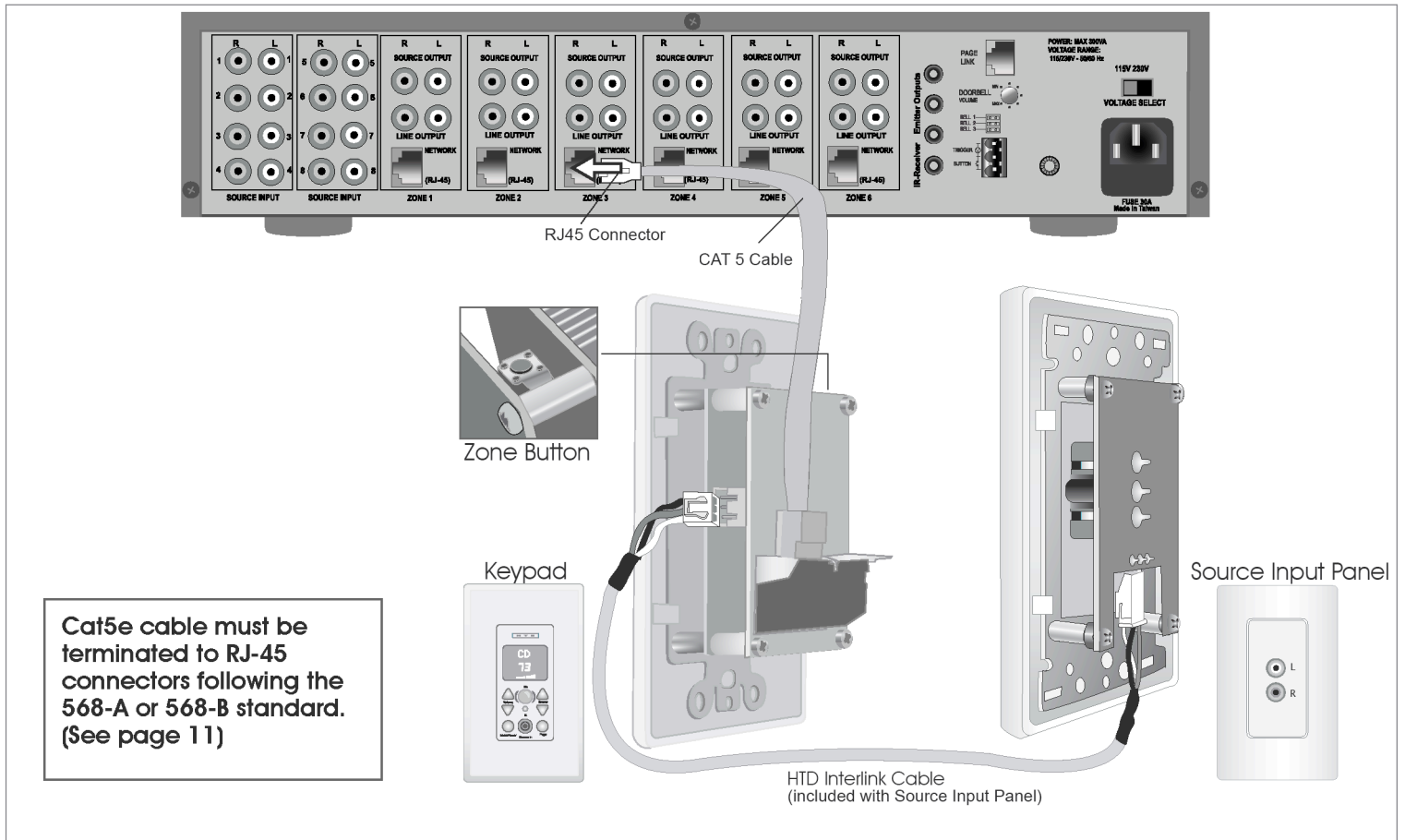

Each keypad can be connected directly to the MC2-86 (option "A") or can be "daisy-chained" to another keypad that is connected to the MC2-86 (option "B"). The Zone Button on each keypad determines the zone number that it controls; select 1, 2, 3, 4, 5, or 6. Note that additional settings, including 7 thru 16 are available for combining up to three MC2-86s (for paging). Please contact us for more details since this option requires modification to the second and third MC2-86. It is not necessary for a Keypad with a Zone Button setting of "X" to be connected to the Network RJ-45 input for Zone "X" (see option "B").

When more than one keypad is set to the same zone number, adjusting the setting of one keypad (either by pressing buttons on that keypad or using a remote control for that keypad) will adjust other keypad(s) set to the same zone number.

Although combinations of Option "A" and "B" are acceptable and very often necessary, we highly recommend connecting at least one keypad from each zone directly to the MC2-86 as shown in option "A" in order to make use of an audio component located within that zone. Each Cat5e cable that connects directly from a keypad to the MC2-86 can carry the audio signal of only ONE audio component (see "NOT OK" above).

# How to Connect (CONT'D)

## 3. Connecting The Amplifier

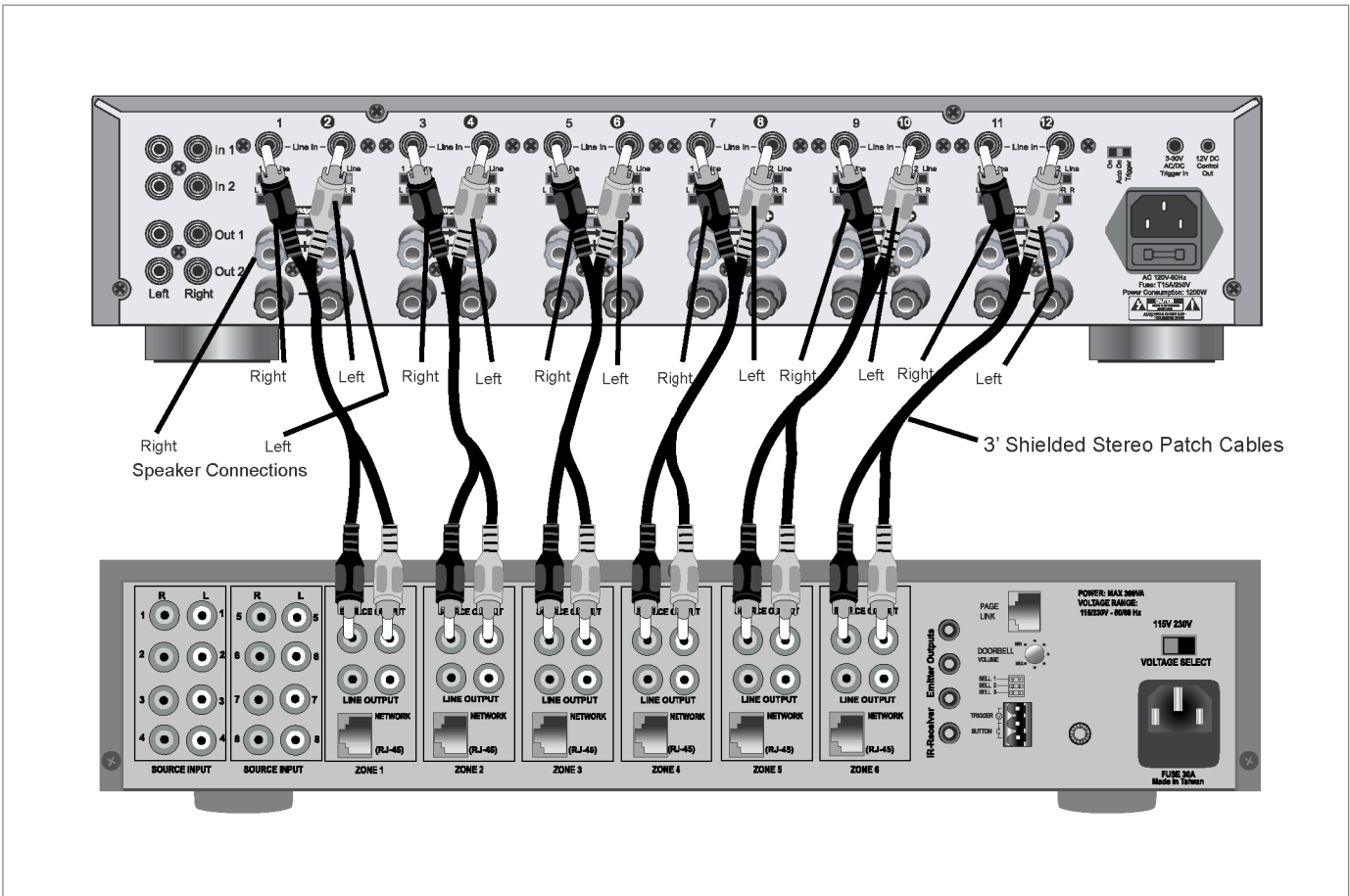

Use the Line Outputs on the MC2-86 to connect to the Line Inputs on the amplifiers for each zone. We include six 3' shielded stereo patch cables with the MC2-86 for this purpose. The diagram above shows the recommended connection to our DMA-1240 12-channel amplifier.

### Amplifier Settings

Two side-by-side amplifiers are used for each zone. One side is set to amplify the Right channel of a stereo signal and the other side is set to amplify the Left side of a stereo signal. In our diagram, channel 1 is set to amplify the Right channel and channel 2 is set to amplify the Left channel for the speakers in Zone 1.

**Level:** Turn the rotary Level knob all the way clockwise to get the maximum power out of the amplifier. You can set the Level at less than maximum to limit the volume output in a zone (e.g. limit how loud a child can play his/her music).

**Input Selection Switch:** Set to "Line".

**L, L+R, R Switch:** When the "Line" input is used, this switch is inactive so the setting is irrelevant. However, you might want to set odd numbered channels to Right (R) and even channels to Left (L) just to make it easier to recall which Line Output from the MC2-86 is being sent to each channel.

**Bridge Switch:** Since you are not bridging the two channels, make sure the Bridge Switch is off (far left position). See the owner's manual for the amplifier for instructions on bridging adjacent channels to achieve even higher power when necessary.

**On - Auto On - Trigger Switch:** Setting this switch to "Trigger" is best when using the MC2-86 with an HTD multi-channel amplifier. A mono 3.5mm patch cable should be connected from the Trigger Out on the MC2-86 to the Trigger In on the multi-channel amplifier. The "trigger" is only active when a Keypad is powered on which means the multi-channel amplifier is only active when a Keypad is on. When all Keypads are off, the multi-channel amplifier will automatically return to sleep mode.

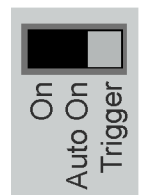
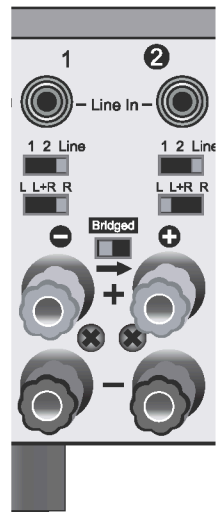

# How to Connect (CONT'D)

## 4. Connecting Source Inputs

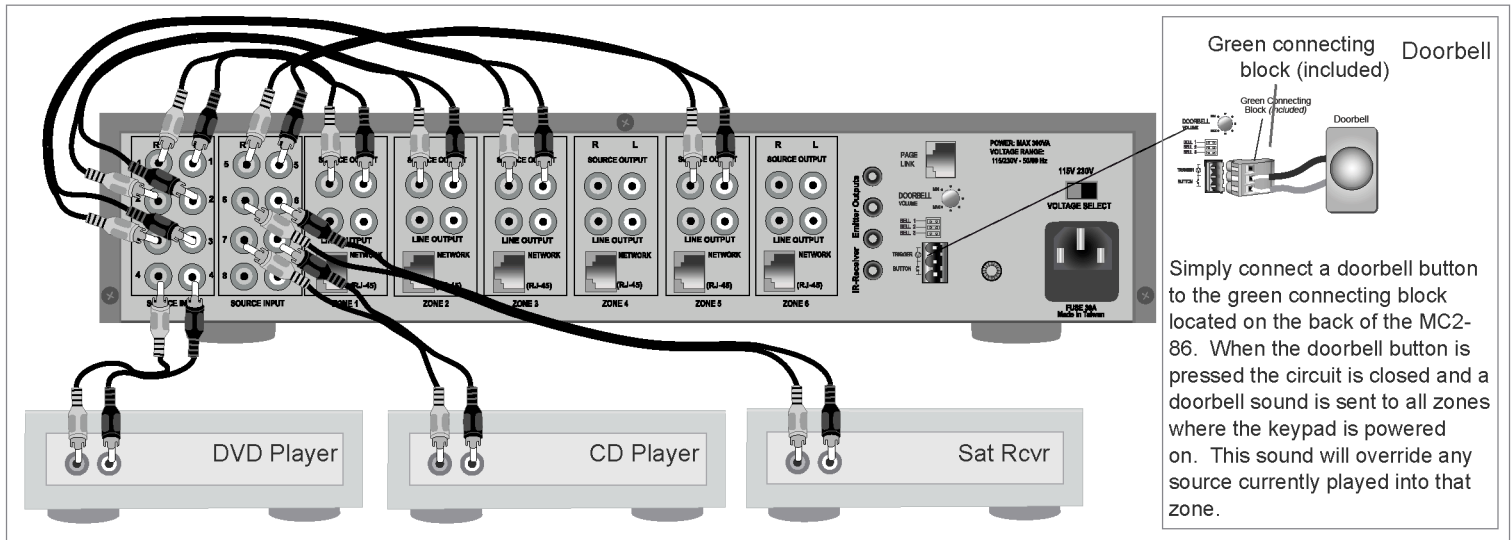

The MC2-86 allows you to select from up to 8 audio components, including up to 6 located throughout your home. In order to make use of an audio component located within a zone, including an audio component connected to the 3.5mm (1/8") input jack on a keypad, on the back of the MC2-86 you must connect the Source Output for that zone into one of the Source Inputs. We include six 1' shielded stereo patch cables for this purpose.

In the example above, we have assigned the source located within Zone 1 to Source Input 1; the source in Zone 2 to Source Input 2; the source in Zone 3 to Source Input 3; and the source in Zone 5 to Source Input 5. Note that Zones 4 and 6 are not wired to provide a source from within those zones. Three centralized sources located near the MC2-86 have been assigned to Source Inputs 4, 6, and 7. Source Input 8 is still available for a future audio component.

## 5. Making use of Infrared (IR) Capability (IR Receiving Eye, Emitters and RC1 remote are sold separately)

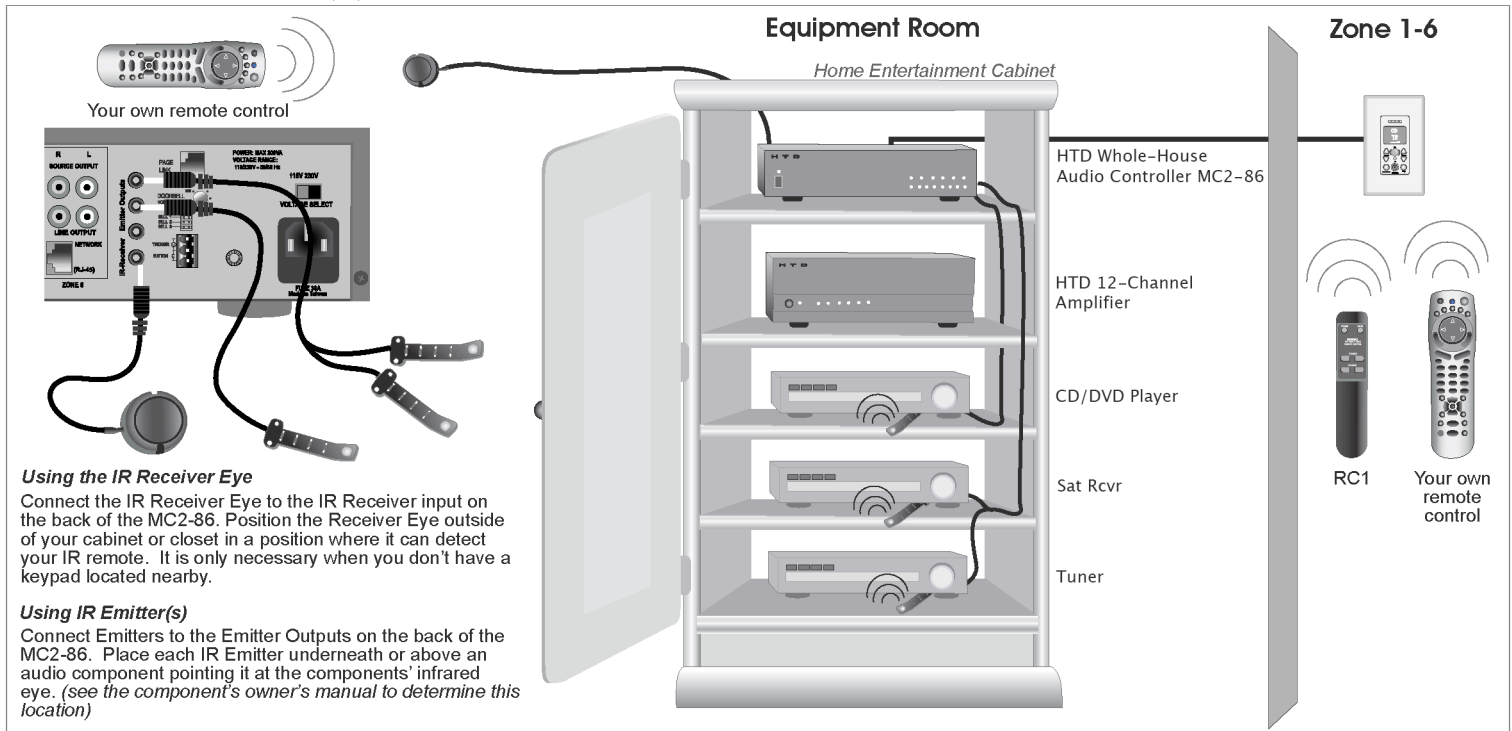

The MC2-86 is capable of passing infrared signals to other components positioned near it. When an infrared remote control is aimed at a Keypad the signal is transmitted through the Cat5e cable to the MC2-86 and on to other components through the use of IR emitters. In this way, you can control these centralized components from within each zone.

If you need to control the components located near the MC2-86 when they are positioned out of sight, such as inside a cabinet or closet, and there is not a Keypad close by, you can connect an IR Receiver Eye directly to the IR-Receiver input on the back of the MC2-86. Place the "Eye" within 15 feet of where you will operate your remote control.



# How to Program the Keypads

Each Keypad has been preset at the factory with a default zone number of "01". The 8 sources have been initially assigned the name "SRC1", "SRC2", "SRC3", etc. and the Page Group is set to "07" (all zones). Each of these settings will need to be changed in order to customize the Keypad for your situation.

## Setting the Zone Number:

The zone number MUST be set BEFORE the keypad is installed in the wall and BEFORE any changes are made to the Source Name and Page Group. Make sure the keypad is properly connected to the MC2-86 with Cat5e cable (properly terminated to standard 568-A or 568-B see page 11) and that the MC2-86 is powered on. Press the power button on the keypad to turn it on. Lightly press the Zone Button on the back of the keypad one time and the zone number will be displayed on the LCD screen. Press and release the Zone Button again to increment the zone number one by one until the zone number you require is displayed. There are 16 possible zone numbers. Only 1-6 should be used if you own one MC2-86 system; 1-12 should be used for two MC2-86s; and 1-16 should be used for three MC2-86s. Once the zone number has been assigned, you can install the keypad into the wall since all remaining programming will be performed using the buttons on the front of the keypad.



**WE HIGHLY RECOMMEND SETTING THE ZONE NUMBERS ON EVERY KEYPAD BEFORE PROCEEDING FURTHER WITH ASSIGNING SOURCE NAMES AND PAGE GROUPS.** *(Doing so will reduce the possibility of accidentally erasing programming on one keypad while changing the zone number on another keypad.)*

## Assigning Source Names

Once all keypads have been assigned a zone number, you can begin assigning source names to each of your 8 possible source components. Note that when a source component does not exist, or you choose to not have that source available within a zone, you will assign the source name "NA" to that source number. During operation, "NA" will not appear on the LCD screen; instead this source will simply be skipped.

- 1.) To enter the Source Name setup screen, press and hold the Source Up button for approx 7 seconds. The text "NAME- Y" will appear for a moment and the IR indicator light will begin blinking.
- 2.) Press the Volume UP or Volume DOWN buttons to identify the Source # (1-8). The Source # is displayed to the right of the volume level numbers on the LCD display and corresponds to the Source Input number on the back of the controller. (note: the Source # will be displayed for about 10 seconds and will then disappear, but you can continue assigning a Source Name to that Source # until you are ready to assign the next Source #.)
- 3.) Once Source # 01 is displayed, use the Source UP and Source DOWN buttons to scroll through the list of Source Names until you select the name you want to use for the component source plugged into Source Input 1. See table at right. The manufacturer-set default Source Names are "SRC1", "SRC2", "SRC3", etc.
- 4.) Repeat steps 2 and 3 for each of the 8 Sources. Remember to select "NA" for any Source Input in which no component source is connected or if you want to skip that source in that zone.
- 5.) Once all 8 sources have been assigned a Source Name, press the Page button to exit setup. Please note that after 10-15 seconds of inactivity the keypad will also automatically exit setup, saving your last settings. The text "NAME-N" will appear for a moment and the IR indicator light will stop flashing once you exit setup. (note: the IR indicator light will sometimes remain lit after exiting setup; if this occurs power off the keypad and then power back on).

## Source Names

Display	Description
TV-2	Television
TV	Television
PHONE	Typically used for mobile phones with audio capabilities
MP3	MP3 Player
POD-2	iPod®, iPod® dock, or similar device
POD	iPod®, iPod® dock, or similar device
SERVR	Media Server
COMP	Computer
CABLE	Cable box
SATRD	Satellite Radio
SATTV	Satellite TV
DVD	DVD Player
CD-2	Compact disc player
CD	Compact disc player
RADIO	Radio
TUNER	AM, FM, or HD Tuner
NA	Not Available - used to denote a source input that has no component connected to it or to identify a source component that should be skipped (not available) in that zone
BABY	Baby room - often used to denote a monitoring device placed in a baby's room
AUX-2	Auxiliary
AUX	Auxiliary

# How to Program the Keypads *(CONT'D)*

## **Assigning Page Groups**

Each keypad can be set up to page a single zone, a group of zones, or all zones. The default setting is all zones. To assign a group or individual zone, follow these instructions:

- 1.) To enter the Page Group setup screen, press and hold the Source Down button for approx 7 seconds. The text "PAGE-Y" will appear for a moment and the IR indicator light will begin blinking.
- 2.) Press the Volume UP or Volume DOWN buttons to identify the Page Group (1 thru 20) you wish to assign to that keypad. See table at right.
- 3.) Press the Page button to exit setup. Please note that after 10-15 seconds of inactivity the keypad will also automatically exit setup, saving your last settings. The text "PAGE-N" will appear for a moment and the IR indicator light will stop flashing once you exit setup. (note: the IR indicator light will sometimes remain lit after exiting setup; if this occurs, power off the keypad and then power back on).

## **PAGE GROUPS**

<b>Group Number</b>	<b>Zone(s) Included</b>
01	1
02	2
03	3
04	4
05	5
06	6
07	ALL (default)
08	1,2
09	1,2,3
10	1,2,3,4
11	7
12	8
13	9
14	10
15	11
16	12
17	7,8
18	7,8,9
19	7,8,9,10
20	7,8,9,10,11,12,13,14,15,16



**Repeat "Assigning Source Names" and "Assigning Page Groups" for each keypad**

# How TO USE

Now that your system is installed you are ready to begin enjoying the convenience and flexibility of the MC2-86 whole-house audio control system.

## **Using the Keypad**

The Keypad is designed to be user-friendly so that it is not intimidating and anyone can use it the first time.

**PLEASE NOTE:** The keypad will enter “sleep mode” after approx 20 seconds of inactivity. To “wake up” the keypad, simply press any button. Once awake, the following functions are ready to be used:

**Volume:** (two buttons) The top button increases volume and the bottom button decreases volume. The volume level is displayed on the LCD screen with a range of 00 to 99 as well as a 10-position bar graph. This wide range is designed to accommodate audio components of varying fixed output levels.



*Should you discover that one or more of your source components has a lower fixed output level than the rest of your components (as is common with some MP3 players and computers), HTD offers two “gain boosters” (models LGB-1 and LGB-4) that are extremely helpful in improving the quality of the sound and in balancing all source levels to a common baseline. Call or email us for more information or check out the whole-house audio accessories section on our website, [www.htd.com](http://www.htd.com).*

**Source:** (two buttons) Use the top and bottom source LCD buttons to scroll through the sources available to the zone that you are in. The Source Name will be displayed on the LCD screen.

**Mute/Power:** Press this button to turn the keypad on. Once powered on, press the button to mute the speakers in that zone. When muted, the LCD will display the word “MUTE”. When a zone is muted, the speakers in that zone are still available for the doorbell and paging. Press and hold this button for approximately 3 seconds to turn off power to the keypad. When off, the speakers in that zone are not available for the doorbell and paging.

**All ON/OFF:** It is possible to turn all of the zones in the system on or off from any keypad. When turning All ON, every keypad will turn on to its last setting prior to being turned off. To turn All ON: Starting with a keypad that is powered off, press and hold the power button for approximately 3 seconds to turn the keypad on. Continue holding for another 4 seconds and all keypads will power on. Release the power button. To turn All OFF: Starting with a keypad that is powered on, press and hold the power button for approximately 3 seconds to turn the keypad off. Continue holding for another 4 seconds and all keypads will power off. Release the power button.

**Page:** Press and hold this button down to override every zone in the Page Group (see page 9) that is currently powered on. Speak with your mouth about 4” to 12” away from the Keypad’s built-in microphone (labeled “mic”). Release the button to resume music listening.

## **Using the Remote Control**

We provide a simple infrared remote control that has the same functionality (without the page feature) as the Keypad. The one exception is separate Power and Mute buttons.

## **Using Your Own Remote Control**

You may want to use your own universal or learning remote control to control the Keypad functions as well as the functions of the centralized components. To do this, you will need to purchase at least one of our Remote Controls and then follow the instructions provided with your learning remote control to teach it to control volume, source selection, power, and mute.

## **Using Hand-Held Audio Components with Variable Output**

Mobile or hand-held audio components, such as an MP3 player or iPod®, can easily be connected to a Source Input Panel using a patch cable with a 3.5mm (1/8”) stereo plug on one end and stereo RCA-type plugs on the other end. These devices can also be connected directly to the 3.5mm (1/8”) input jack on the Keypad using a patch cable with a 3.5mm (1/8”) stereo plug on both ends. The “output” on these devices is often the stereo headphone output jack. This output level is variable, meaning the output level is controlled by the component’s volume control. It is usually best to set the volume on these devices somewhere between half-way up and maximum when using them with the MC2-86 system. However, in some cases you will need to reduce this output level in order to prevent distortion (especially if operating on battery power).

(this page is intentionally blank)

# Whole-House Audio Control Addendum

## Connecting RJ-45 Plugs to Cat5e Cable

Please use a standard (T-568A or T-568B) "Straight-Through" RJ-45 connection with Cat5e cable (Cat5, or Cat6 are acceptable) to connect the Keypad to the MC2-86 or a Keypad to another Keypad. A "Straight-Through" connection means that the Cat5e wires are attached in exactly the same order inside the RJ-45 plug at both ends of the cable. Never use a cable with a "Crossover" connection in which the two ends of the cable are wired differently.

When running your Cat5e cable, you have two options: 1) use cable of predetermined lengths that have the RJ-45 plugs attached by the manufacturer, or 2) use a crimping tool to attach the RJ-45 plugs yourself after you have run the Cat5e cable. With option 1) you don't have to worry about the connections being solid and correct, but you'll likely have to cut larger holes through the framework of your house to get the cables into position. This option will cost a little more because you are likely to have excess cable since you can only buy in predetermined lengths. Option 2) allows you to buy your Cat5e cable in bulk and run exactly the length you need for each connection. But you'll have to terminate each end with an RJ-45 plug yourself.

If you decide to add the RJ-45 connections yourself, make sure you wire the plugs using a "Straight-Through" standard. The T-568A standard is supposed to be used in new network installations. However, most off-the-shelf Ethernet cables (Cat5e cables with RJ-45 plugs) are still of the T-568B standard; either standard is suitable for use with the MC2-86.

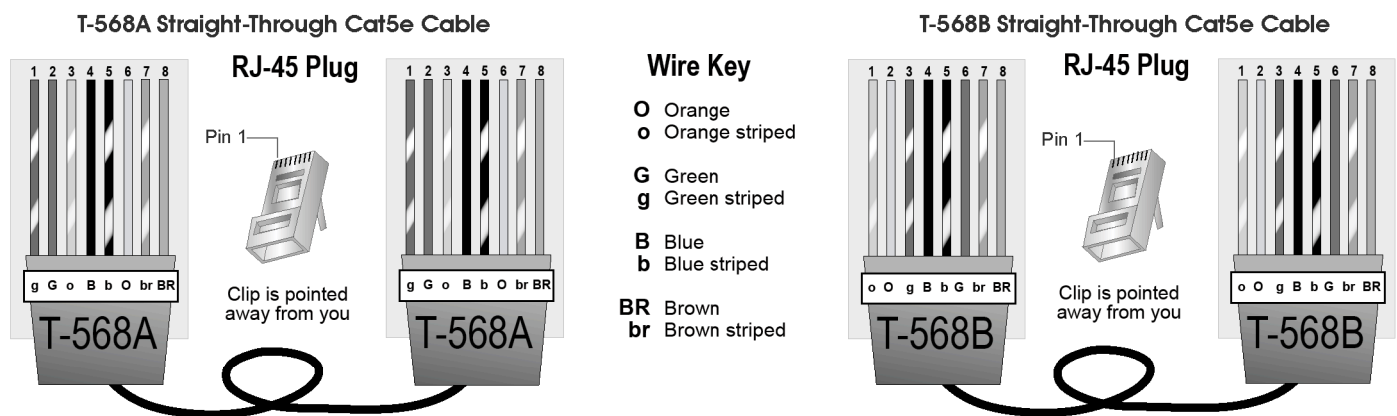

### Instructions:

Start on one end and strip the cable jacket off (about 1") using a stripper or a knife. Be extra careful not to nick the wires, otherwise you will need to start over.

Spread, untwist the pairs, and arrange the wires in the order of the desired cable end. Flatten the end between your thumb and forefinger. Trim the ends of the wires so they are even with one another, leaving only 1/2" in wire length. If it is longer than 1/2" it will be out-of-spec and susceptible to crosstalk. Flatten and insure there are no spaces between wires.

Hold the RJ-45 plug with the clip facing down or away from you. Push the wires firmly into the plug. Inspect that each wire is flat and even at the front of the plug. Check the order of the wires. Double check again. Check that the jacket is fitted right against the stop of the plug. Carefully hold the wire and firmly crimp the RJ-45 with a special RJ-45 crimping tool.

Check the color orientation, check that the crimped connection is not about to come apart, and check to see if the wires are flat against the front of the plug. If even one of these are incorrect, you will have to start over.

### Tips for Running Cat5e and Connecting to RJ-45:

- If you are pulling cables through holes, it is easier to attach the RJ-45 plugs after the cable is pulled.
- Odd numbered pins are always striped, even numbered pins are always solid colored.
- Looking at the RJ-45 with the clip facing away from you, Brown is always on the right, and pin 1 is on the left.
- No more than 1/2" of the Ethernet cable should be untwisted otherwise it will be susceptible to crosstalk.
- Do not deform, do not bend, do not stretch, do not staple, do not run parallel with power cables, and do not run Cat5e cables near noise inducing components.

# Whole-House Audio Control Addendum

## Using More Than One MC2-86 Controller

**\* PLEASE CONTACT HTD IF YOU PLAN TO COMBINE TWO OR THREE MC2-86 CONTROLLERS FOR UP TO SIXTEEN (16) UNIQUE ZONES. WE WILL MODIFY THE SECOND (AND THIRD) MC2-86 CONTROLLERS FOR THIS PURPOSE BEFORE SHIPPING THEM TO YOU \***

It is possible to achieve a total of 16 zones by combining three MC2-86 controllers together. This will allow every zone to Page every other zone. A doorbell connected to any one of the MC2-86 controllers will also be available to all zones. To connect two MC2-86 controllers together simply connect a Cat5e cable between them using the RJ-45 connections shown below. To add a third MC2-86 controller you will need to add a three-way adapter that we supply free-of-charge with the purchase of your third MC2-86 controller.

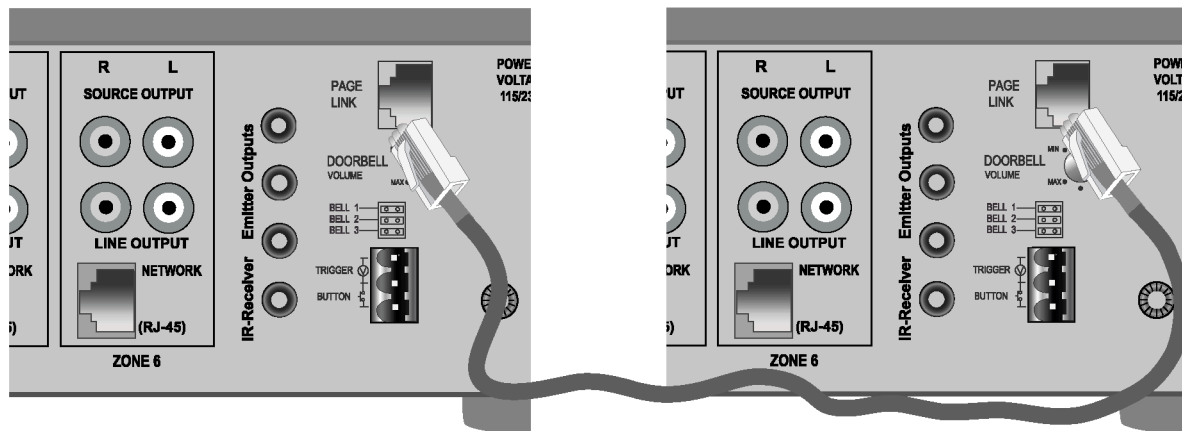

## Sharing Sources Across Multiple MC2-86 Controllers

Up to 8 audio devices can be connected to each MC2-86 controller. Every keypad attached to that controller can select between those devices. Using "Y-adapters", it is possible to connect a single audio device (even one originating from a zone on a different MC2-86 controller) into multiple MC2-86 controllers, making it available to all zones.

In the example below:

- CD Player 1 is available to zones 1,2,3,4,5,6
- CD Player 2 is available to zones 7,8,9,10,11,12
- The tuner and the audio device located in zone 5 are available to all zones

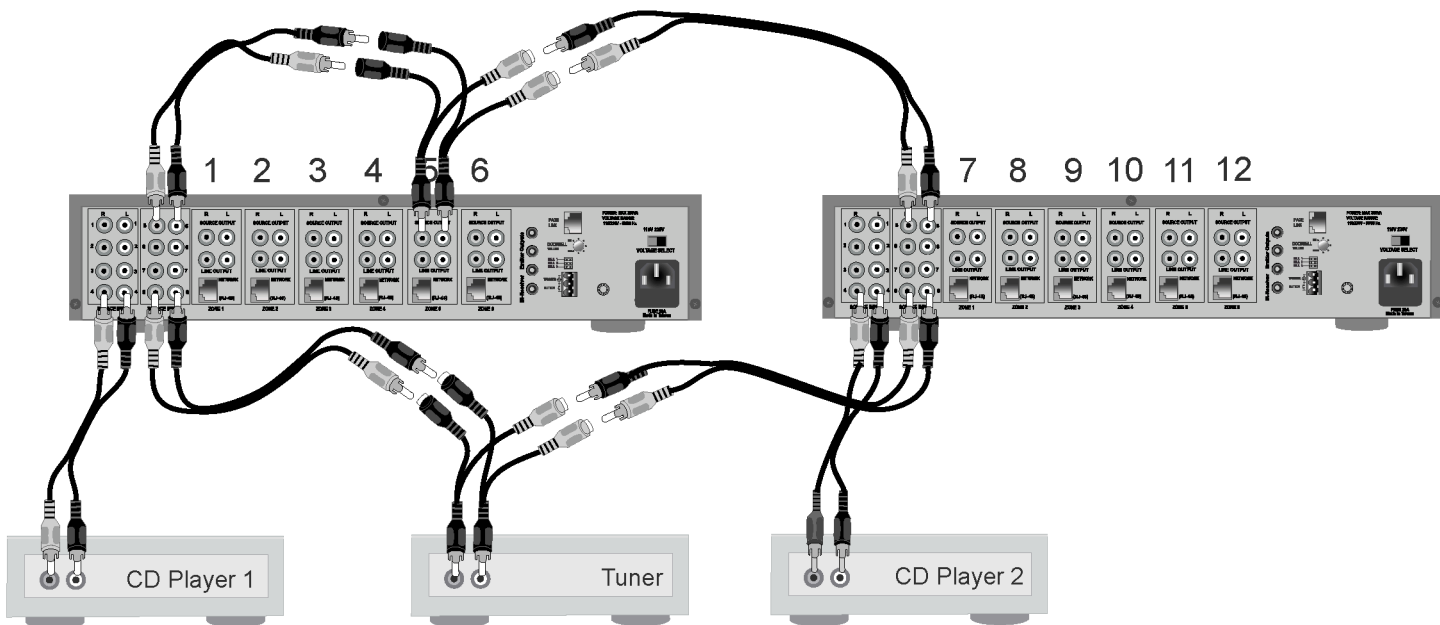

## Whole-House Audio Control Addendum

### Troubleshooting:

**If you are receiving no sound within one or multiple zones** - make sure each channel on the 12-channel amplifier is set to "Line" (see page 6).

### Notes:

It is possible to create "Sub-Zones" by adding rotary volume controls to each pair of speakers in a "Sub-Zone". These volume controls are installed "in-line" between the amplifier and the speakers. Please contact HTD for more details.

Because the MC2-86 Controller is completely separate from the amplifier, this system provides the flexibility of being able to add unlimited speakers and amplifiers into each zone.

® iPod is a registered trademark of Apple Computer, Inc.

**HTD**

Home Theater Direct

Toll free: 866-HTD-AUDIO (483-2834)

[www.htd.com](http://www.htd.com)

[info@htd.com](mailto:info@htd.com)