



MA-1235 & MA-1265  
12-Channel Amplifier  
Owner's Manual

Home Theater Direct, Inc.  
[www.htd.com](http://www.htd.com)

Expert Support:  
866-HTD-AUDIO (483-2834)  
[info@htd.com](mailto:info@htd.com)

# SAFETY INSTRUCTIONS

**Warning** - To reduce the risk of fire or shock, do not expose this appliance to rain or moisture.

**Caution** - To reduce the risk of fire or shock, do not remove the cover or back. No user serviceable parts inside.  
Refer servicing to qualified service personnel.

**Caution** - To prevent electric shock, match wide blade of plug to wide slot, fully insert.



The lightning flash with arrowhead symbol, within an equilateral triangle, is intended to alert the user to the presence of un-insulated dangerous voltage within the product's enclosure that may be of sufficient magnitude to constitute a risk of electrical shock to persons.



The exclamation point within an equilateral triangle is intended to alert the user to the presence of important operating and maintenance (servicing) instructions in the literature accompanying this appliance.



## Read Instructions

All the safety and operating instructions should be read before the appliance is operated.

## Retain Instructions

The safety and operating instructions should be adhered to.

## Heed Warnings

All of the warnings on the appliance and in the operating instructions should be adhered to.

## Follow Instructions

All operating and use instructions should be followed.

## Water and Moisture

The appliance should not be used near water. For example, near a bathtub, washbowl, kitchen sink, laundry tub, in a wet basement, or near a swimming pool, etc.

## Ventilation

The appliance should be situated so that its location or position does not interfere with its proper ventilation. For example, the appliance should not be situated on a bed, sofa, rug, or similar surface that may block the ventilation openings. Never place the appliance in a confined space such as a bookcase, or built-in cabinet, unless proper ventilation is provided.

## Heat

The appliance should be situated away from heat sources such as radiators, heat registers, stoves, or other appliances that produce heat. Position the appliance at least 5" away from any heat-producing equipment, including other HTD amplifiers.

## Power Sources

The appliance should be connected to a power supply only of the type described in the operating instructions or as marked on the appliance.

## Grounding or Polarization

Precautions should be taken so that the grounding or polarization means of an appliance is not defeated.

## Power Cord Protection

Route the power cord so that it is not likely to be walked on or pinched by items placed upon or against them, paying particular attention to the plugs, receptacles, and the point where the cord exits from the appliance.

## Cleaning

Unplug the appliance from the wall outlet before cleaning. Do not use liquid cleaners or aerosol cleaners. Use a cloth lightly dampened with water for cleaning the exterior of the appliance only.

## Non-Use Periods

The power cord of the appliance should be unplugged from the outlet when left unused for long periods of time.

## Object and Liquid Entry

Care should be taken so that objects do not fall and liquids are not spilled into the enclosure through openings.

## Damage Requiring Service

The appliance should be serviced by qualified personnel when:

- the power supply cord or the plug has been damaged
- objects have fallen, or liquid spilled into the appliance
- the appliance has been exposed to rain
- the appliance does not appear to operate normally or exhibits a marked change in performance or
- the appliance has been dropped, or the enclosure damaged

## Servicing

The user should not attempt to service the appliance beyond that described in the operating instructions. All other servicing should be referred to qualified service personnel.

## Product Servicing

If your system fails to operate properly, please contact HTD directly for further assistance at 1-866-483-2834.

Additional information, including detailed specifications for each model, can be found on our website, [www.htd.com](http://www.htd.com). Thanks again for choosing Home Theater Direct!

**Warranty:** The MA-1235/MA-1265 carries a two-year parts and labor warranty. Should your MA-1235/MA-1265 fail to operate properly at any time during the warranty period, HTD will repair or replace (at our option) the item barring any indication of misuse or abuse. Freight to an HTD authorized facility is paid by the customer. Return freight is paid by HTD. Warranty registration occurred automatically at the time your order was placed. There is no need to complete or mail in additional paperwork. Prior to returning any item, please call 1-866-483-2834 to receive a Return Authorization number.

# INTRODUCTION

Thank you for giving Home Theater Direct the chance to win your business! We are confident you will find that HTD offers an outstanding combination of performance and value in everything we make. To ensure you get the most out of your new amplifier, please take a moment to read this manual before you get started. Should you lose this manual, you can always download or print a copy from [www.htd.com](http://www.htd.com).

The MA-1235 (MA-1265) is a 12-channel, multi-use, multi-zone power amplifier that is flexible and powerful enough to amplify every speaker in your whole-house audio system and/or home theater system. This amplifier delivers exceptionally accurate sound and is designed to deliver trouble-free performance for many years to come. Each channel delivers 35 watts RMS (65 watts RMS for MA-1265) into 8 ohms and 50 watts RMS (100 watts RMS for MA-1265) into 4 ohms with all channels driven. In addition, you can choose to bridge adjacent channels (eg. 1 and 2) to create a single 100 watt RMS (150 watts RMS for MA-1265) channel. This allows for a multitude of set-up options for virtually any application that requires multiple discreet channels of amplification.

This owner's manual is designed to get you quickly up and running with your new system. Should you have any questions, we are available by phone, toll free 866-HTD-AUDIO (866-483-2834) M-F 8am-6pm, and by email at [info@htd.com](mailto:info@htd.com).

## GENERAL GUIDELINES

***Please read the following warnings and tips before hooking up your MA-1235/MA-1265:***

- Never connect speaker wire or line level connections with the front power button in the ON (in) position. Always make your connections with the amplifier OFF.
- Only use the detachable power cord supplied with your MA-1235/MA-1265. It is a 3-prong, grounded power cord.
- Never disable the ground wire in the power cord. This is for your protection.
- Never plug the MA-1235/MA-1265 into the back of another electrical component.
- We highly recommend plugging the MA-1235/MA-1265 into a power tree with adequate surge protection.
- Dual banana plugs (sold separately) will fit the speaker connections in each individual channel, but will not fit across the two red posts when operating side-by-side channels in bridged mode. We offer single banana plugs (sold separately) for this purpose.

***If you have any questions, we can be reached at...  
[info@htd.com](mailto:info@htd.com) or toll free 1-866-HTD-AUDIO (483-2834)***

# PRODUCT FEATURES

Included with MA-1235  
and MA-1265  
(1) Power cord



**Top panel air vents** allow unwanted heat to escape the inside of the amplifier chassis. For proper ventilation, please allow at least 5 inches of open air space above this component. If the amplifier is placed inside of a cabinet, please make sure the cabinet is well ventilated to prevent overheating.



**Power On/Off Button**

Press "In" to turn amplifier "ON"  
Press again (to OUT position)  
to turn amplifier "OFF"

**Power Indicator Light**

Low intensity = Standby  
High Intensity = ON

**Channel Protection Lights**

Every channel is designed with a "Protection Mode". These Red lights will turn ON when a channel goes into "Protection Mode" and will automatically turn OFF when the problem has been solved.

**Power Button:** Press this button in to turn the amplifier "ON". Press this button again to turn the amplifier "OFF".

**Power Indicator Light:** The front blue power light has two intensities. Low intensity indicates the component is plugged in, the Power Button is pressed in, and the amplifier is in stand-by mode. The blue light will be in low intensity/stand-by mode until the amplifiers are activated based on the setting of the "Power mode switch" found on the back side of the amplifier. Once the amplifier is activated, the blue power light will shine with higher intensity.

**Channel Protection Lights:** Every amplifier channel includes a protection circuit designed to prevent the amplifier from being damaged as a result of improper speaker installation. A channel will go into protection mode if: 1.) the impedance from the speakers drops below 4 ohms, or 2.) a short exists across the positive and negative lines of the speaker cable or connection points. When this happens, the other channels will continue to operate normally and a red light on the front panel corresponding to the protected channel will turn on. Once conditions return to normal, the affected channel will resume operation and the red light will turn off.

**Power mode switch** determines if the component is always on (ON), turns on when an input signal is sensed (AUTO-ON), or turns on when triggered by another component (TRIGGER).

**2 pairs of gold-plated stereo inputs** are available to all channels.

**2 pairs of gold-plated stereo outputs** are available to pass along the signals received in the two stereo inputs.

**Variable Level Controls for each channel** make limiting or balancing maximum volume levels throughout your home easy.

**An individual gold-plated Line input** is available to each channel.

**Input selection switch** for determining input source that each channel plays - choose from input 1, input 2, or the dedicated Line input.

**Select Left, Right, or Left+Right (mono)** to determine which signal from input 1 or input 2 is assigned to each channel. This switch is bypassed when the individual Line input is selected.

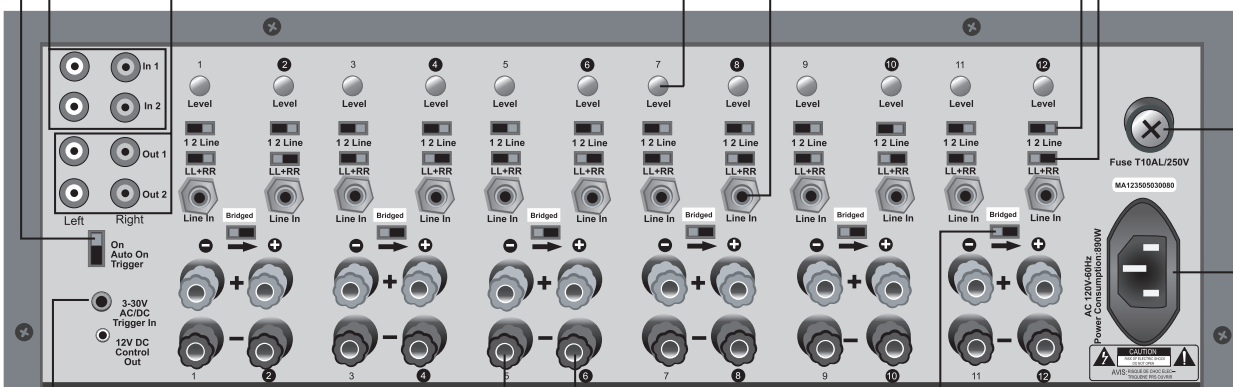

An **external fuse** can be replaced in the event of an unexpected electrical shock to the unit.

**3-prong IEC socket** for connecting the removable power cord.

**1/8" Input trigger jack** - Turns the MA-1235/MA-1265 ON from another component.

**1/8" Output trigger jack** - Turns ON another component from the MA-1235's/MA-1265's signal.

**5-way gold-plated binding posts** for solid connections with speaker cable.

**Bridge switch**

Move this switch to the right to "bridge" adjacent channels. The controls for the Even-Numbered channels (2,4,6,8,10,12) take over in bridged mode.

# PRODUCT FEATURES

**Gold-Plated Connections:** All line level inputs, outputs and speaker connections are gold-plated for clear signal transfer.

**Multiple Inputs:** Any audio component with a stereo analog RCA-type output can be connected to the MA-1235/MA-1265. Two stereo line level inputs (In 1 and In 2) are available to every channel. Plus, every channel has its own dedicated input (Line In). In addition, you can choose to power either the left (L) or right (R) input, or select a summation of the left and right (L+R). This provides incredible flexibility for selecting which signal to amplify through the speaker(s) connected to each channel.

**Stereo Outputs:** Two stereo line level outputs (Out 1 and Out 2) are provided to allow the stereo input signals (In 1 and In 2) to be passed on to additional equipment as needed.

**Power-On Modes:** The MA-1235/MA-1265 can be turned on automatically when an input signal or voltage trigger is sensed. You can alternatively leave the MA-1235/MA-1265 in always-on mode. An output voltage trigger is also available for activating other components as the MA-1235/MA-1265 is turned on.

**Level Settings:** Each channel has its own adjustable Level knob. Use this knob to set the maximum output level for each channel. This feature allows you to easily balance the output volume throughout your home.

**Best practice:** When using separate volume controls or keypads to locally control volume level within a zone, start with the Level setting at the 12:00 position (turned about half-way up). Next, set the volume level on your rotary volume control (sold separately) or digital keypad (sold separately) to its maximum setting for the speaker(s) connected to that channel/zone. Then slowly turn up the Level knob on the back of the MA-1235/MA-1265 until the desired maximum volume level is achieved. This is most easily accomplished with the assistance of a second person. It is acceptable to turn the Level knob to its maximum setting but you can extend the life of the component by only utilizing as much power as necessary.

**Speaker Connections:** Speakers are connected directly to the amplifier using speaker cable. For all behind-the-wall installations, CL3-rated cable is recommended to comply with most building-codes. Speaker cable can be connected to the 5-way binding posts using bare wire, dual or single banana plugs, spade connectors or pins. Be sure to maintain polarity (**Speaker + to Amplifier +, Speaker - to Amplifier -**).

## Speaker Connection Examples

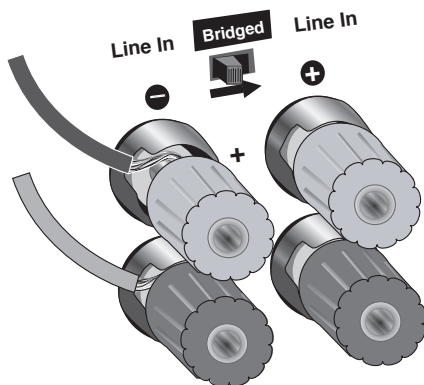

### Bare Wire

Rotate binding post counter-clockwise to reveal post. Strip back 3/8" insulation from cable. Tightly twist copper wires and wrap around post as shown. Rotate binding post clock-wise to tighten.

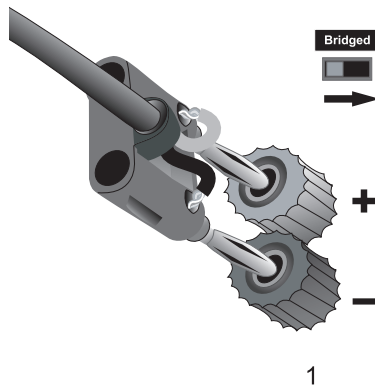

### Banana Plug

Make sure binding posts are tightened then push in banana plug

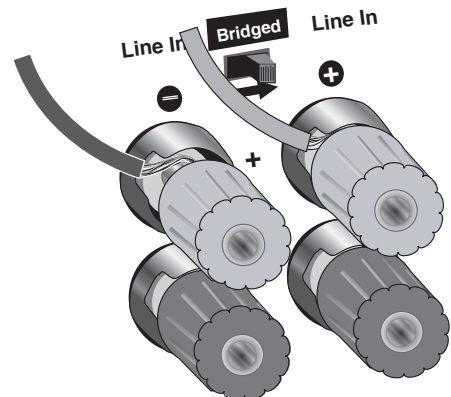

### Bare Wire - Bridged Mode

When bridging two side-by-side channels the top binding post from the odd-numbered channel becomes the negative post and the top binding post from the even-numbered channel becomes the positive post. Dual banana plugs will not fit across these two posts. Single banana plugs, spade connectors, or bare wire should be used in bridged mode. The controls for the even-numbered channels take over in bridged mode.

**THE AMPLIFIER SHOULD BE POWERED OFF (FRONT BUTTON)  
WHEN CONNECTING OR DISCONNECTING SPEAKER CABLES**

# HOW TO CONNECT AND USE THE MA-1235/MA-1265

## Example One: Connecting the Amplifier to an advanced whole-house audio controller, such as the HTD MC-86

Use the Line Outputs on the MC-86 to connect to the Line Inputs on the amplifiers for each zone. We include six 3' shielded stereo patch cables with the MC-86 for this purpose.

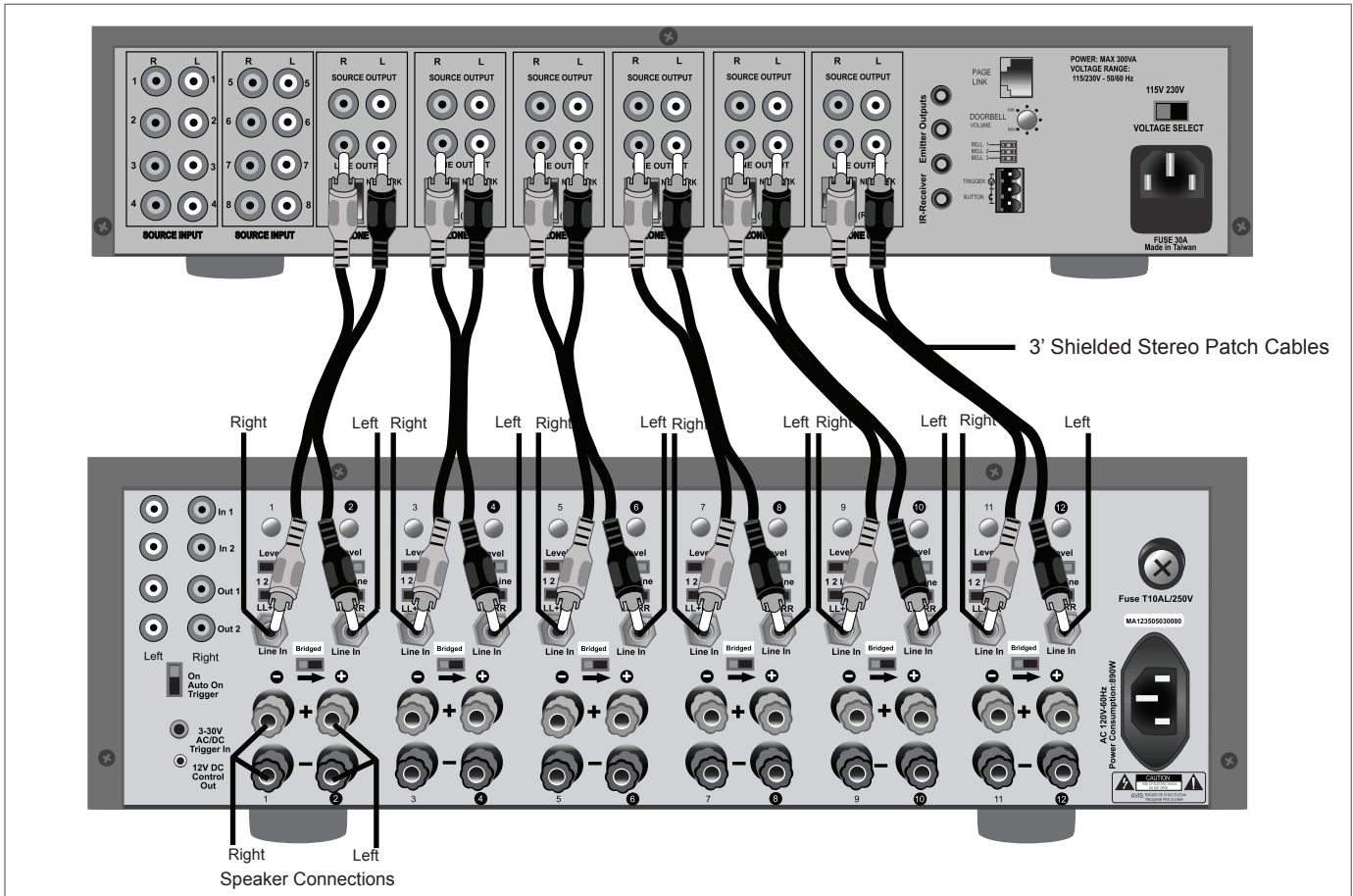

### Amplifier Settings

Two side-by-side amplifiers are used for each zone. One side is set to amplify the Right channel of a stereo signal and the other side is set to amplify the Left side of a stereo signal. In our diagram, channel 1 is set to amplify the Right channel and channel 2 is set to amplify the Left channel for the speakers in Zone 1.

**Level:** Turn the rotary Level knob all the way clockwise to get the maximum power out of the amplifier. You can set the Level at less than maximum to limit the volume output in a zone (e.g. limit how loud a child can play his/her music). See “Best Practices” under Level Settings on Page 4 for more information.

**Input Selection Switch:** Set to “Line”.

**L, L+R, R Switch:** When the “Line” input is used, this switch is inactive so the setting is irrelevant. However, you might want to set odd numbered channels to Right (R) and even channels to Left (L) just to make it easier to recall which Line Output from the MC-86 is being sent to each channel.

**Bridge Switch:** Since you are not bridging the two channels, make sure the Bridge Switch is off (far left position). See the owner’s manual for the amplifier for instructions on bridging adjacent channels to achieve even higher power when necessary.

**On - Auto On - Trigger Switch:** It is best to set this switch to “On” which will always have the amplifier ready to power an input signal, including the doorbell and paging. Additionally, “Auto On” and “Trigger” may not always recognize a low-level source signal coming from the MC-86.

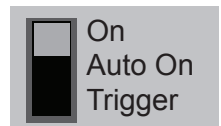
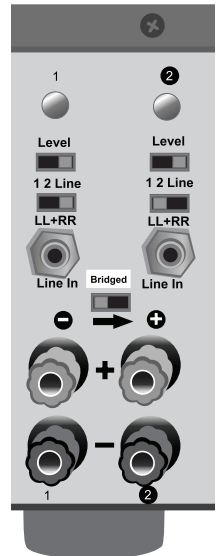

# HOW TO CONNECT AND USE THE MA-1235/MA-1265

## Example Two: Connecting the Amplifier to a home theater receiver or stereo receiver/component

Use the stereo pre-amp or auxiliary outputs on your receiver and/or component to connect to input 1 (In 1) and/or input 2 (In 2) and/or the dedicated Line Inputs on each channel of the MA-1235/MA-1265.

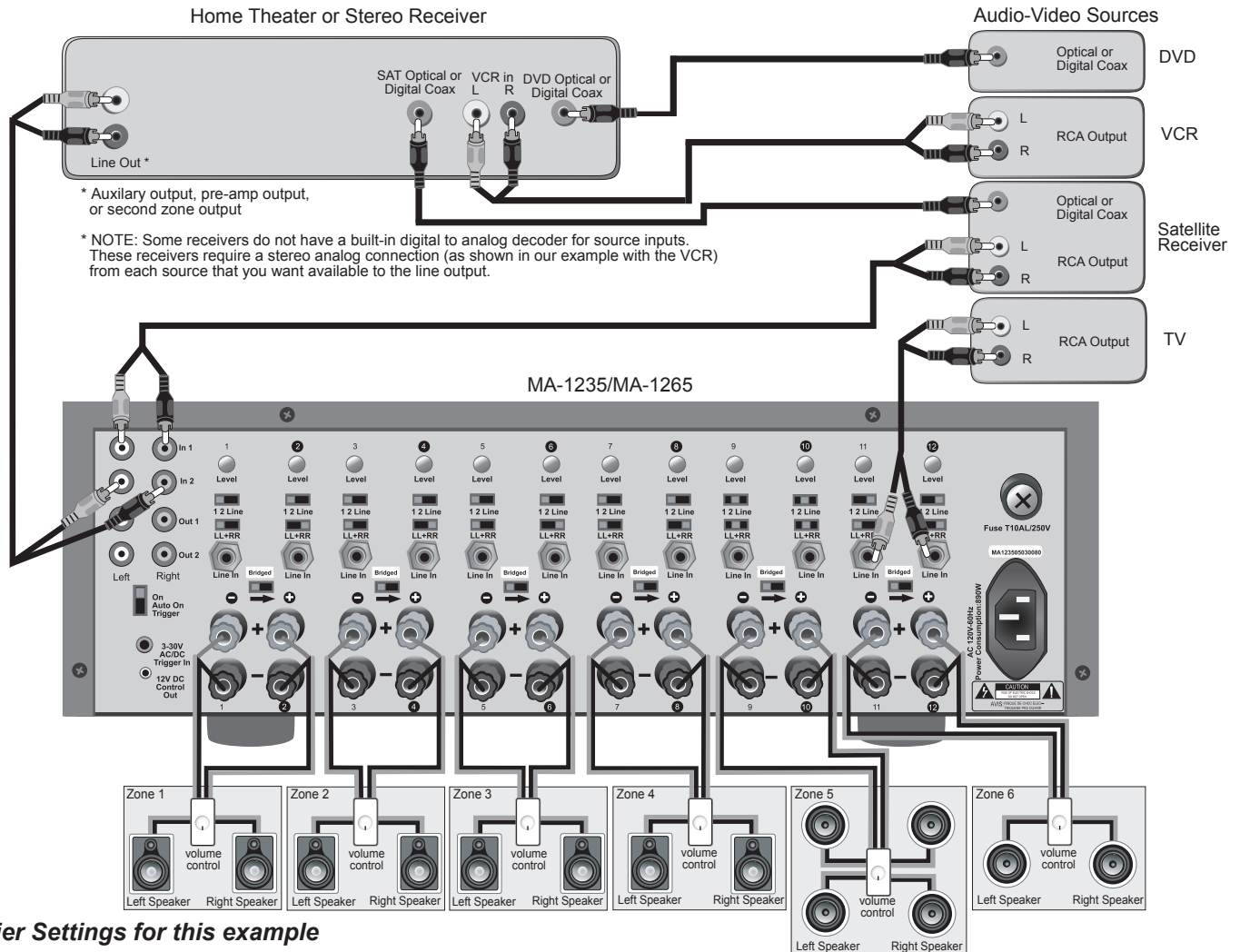

### Amplifier Settings for this example

**Zones 1, 2, 3, and 4** are set up to be stereo zones that amplify the signal from the Satellite Receiver. The Satellite receiver is often set to a user's favorite audio channel so that at any time it can be heard in zones 1, 2, 3 and 4. In this setup, "In 1" is selected and the odd numbered channels are set to "L" for the left channel and the even numbered channels are set to "R" for the right channel. A rotary volume control (sold separately) is placed into each zone to control the volume level from within the zone.

**Zone 5** is set up to amplify the signal being sent out of the home audio receiver's auxiliary line output. In this example, "In 2" is selected and both the odd numbered and the even numbered channels are set to "L+R". With this setting, all of the speakers in this zone are playing the same information which is the sum of the left and right channels. A rotary volume control (sold separately) is placed into this zone to control the volume level from within the zone for all four speakers. The user just as easily could have connected two rotary volume controls into this zone, one for each pair of speakers. Note: Each channel on the MA-1235/MA-1265 is stable down to 4 ohms. So it is safe to connect two 8 ohm speakers to each channel. While it is possible to connect three or more speakers to each channel with the use of impedance matching rotary volume controls (sold separately), it is not recommended since the volume level is significantly reduced.

**Zone 6** is set up to be a stereo zone that amplifies the signal from the bedroom TV. In this setup, "Line" is selected. In this example, the left channel from the TV signal is connected to channel 11 and the right channel is connected to channel 12. When "Line" is selected, the "L, L+R, R" switch is inactive. However, it is usually helpful to set channel 11 to "L" and channel 12 to "R" simply to help keep track of what each channel is amplifying. A Rotary volume control (sold separately) is placed into the zone to control the volume level from within the zone. Note: If the user wanted to change zone 6 to listen to the Satellite receiver (as with Zones 1, 2, 3 and 4), the user simply changes the switch from "Line" to "In 1".

<b>Specifications:</b>	<b>MA-1235</b>	<b>MA-1265</b>
Channels of Amplification: 12 (6 stereo)		
8 ohms RMS Watts Per Channel (all channels driven)	35	65
4 ohms RMS Watts Per Channel (all channels driven)	50	100
Adjacent Channels Bridged @ 8 ohms RMS Watts Per Channel	100	150
Total Harmonic Distortion (THD) 20 Hz - 20 kHz		
8 ohms	.04%	.04%
4 ohms	.06%	.06%
Adjacent Channels Bridged 8 ohms	.09%	.09%
Dimensions (HxWxD)	5.75" x 17" x 17.5"	7" x 17" x 17.5"
Net Weight	49 lbs.	55 lbs.

**HTD**

Home Theater Direct, Inc.  
www.htd.com

Expert Support:  
Toll free: 866-HTD-AUDIO (483-2834)  
info@htd.com